

# INDUSTRIAL THERMOMETER

BIMETAL

**Effex**  
INDUSTRIALSOLUTIONS

## MODEL CODE : ECB

### SPECIAL FEATURES

- STAINLESS STEEL CASE & STEM
- STEM LENGTH AVAILABLE FROM 50 MM
- BOTTOM / BACK / EVERY ANGLE ENTRY
- SILICON OIL FILLED (OPTIONAL)
- WITH OR WITHOUT THERMOWELL
- EXTERNAL ZERO ADJUSTMENT (OPTIONAL)
- STANDARD FOLLOWED EN 13190.

### APPLICATIONS

CHEMICALS / REFINERY / FERTILIZER / PETROCHEMICALS /  
PHARMACEUTICAL / POWER / CEMENT / SUGAR / FOOD &  
BEVERAGES / PULP & PAPER & ALLIED PROCESS INDUSTRIES  
WHICH ARE HAVING CORROSIVE MEDIA / ENVIRONMENT.

### SPECIFICATIONS

**STANDARD VERSION** : 40 mm & 50 mm = Range up to 150 °C Max.,  
63 mm = Range up to 300 °C Max.,  
80 mm, 100 mm, 125 mm & 150 mm = Range up to 500 °C Max.  
(For compound ranges, refer range table)

Accuracy	: Class 1 as per EN 13190
Ambient Temperature	: -25° C to 65° C
Operating Pressure	: 15 kg/cm <sup>2</sup> ( without thermowell )
Over Range Limit	: 120 % of Full Scale
Stem Diameter	: 8 mm
Process Connection	: ½" BSP (M) Adjustable

Case, Bezel & Clamp	: AISI 304 SS
Stem & Connection	: AISI 316 SS
Joints	: Tig argon arc welding
Sensing Element	: Bi - metal strip coiled

Protection	: IP 65
Dial	: Aluminum, black graduation on white background
Pointer	: Aluminum, black coloured, Slotted zero adjustable & Fixed for NS 40 mm, 50 mm & 63 mm
Zero adjustment	: Externally for mounting type 8 & 14, (Except NS 40 mm, 50 mm & 63 mm)
Window	: Sheet Glass
Gasket	: Neoprene

### STANDARD VERSION : SILICON OIL FILLED

Accuracy	: Class 1 as per EN 13190
Ambient Temperature	: Maximum 65°C
Window	: Plexi Glass
Dampening Liquids	: Silicon Oil (Option QA)
Gasket & Filling Plug*	: NBR
Other Features	: Refer Specification of Standard Version

\*Gasket & Filling plug of NBR. Refer Price List for Viton.



Nominal Range, Measuring Ranges & Limits of Error as per EN 13190

Nominal Range (°C)	Measuring Range (°C)	Limits of Error (± °C)
-20 to +40	-10 to +30	1
-20 to +60	-10 to +50	1
-20 to +120	-10 to +110	2
-30 to +30	-20 to +20	1
-30 to +50	-20 to +40	1
-30 to +70	-20 to +60	1
-40 to +40	-30 to +30	1
-40 to +60	-30 to +50	1
-100 to +60	-80 to +40	2
0 to 60	10 to 50	1
0 to 80	10 to 70	1
0 to 100	10 to 90	1
0 to 120	10 to 110	2
0 to 160	20 to 140	2
0 to 200	20 to 180	2
0 to 250	30 to 220	2.5
0 to 300	30 to 270	5
0 to 400	50 to 350	5
0 to 500	50 to 450	5
0 to 600	100 to 500	10

**TEMPERATURE  
GAUGES**

# INDUSTRIAL THERMOMETER

BIMETAL



**MODEL CODE : ECB**

## DIMENSIONS - STANDARD VERSION

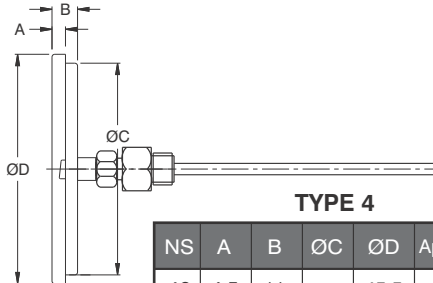
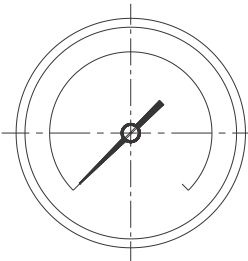
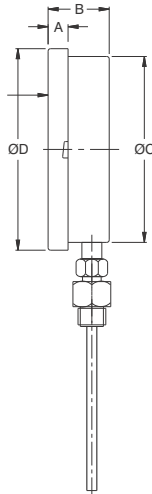
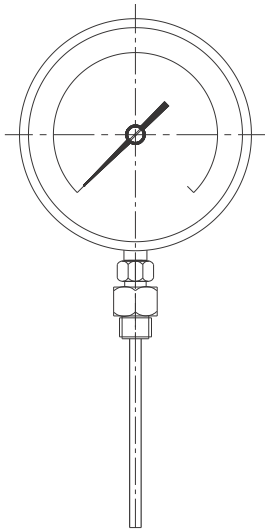

**TYPE 4**

NS	A	B	ØC	ØD	Approx. Wt.#
40	4.5	11	41.5	45.5	100.0
50	6.5	12	51.5	57.5	115.0
63	9.5	16	60	69.5	150.0
80	11	16	80	89.5	250.0
100	9.5	18	100	111	350.0
125	10	20	119	131.5	500.0
150	15	25.5	149	161	750.0

(# Weight in grams with box for 300 mm stem length.)

**TYPE 2**

NS	A	B	ØC	ØD	Approx. Wt.#
63	12.5	46	66.5	77.5	200.0
80	11	46	80	89.5	250.0
100	12.5	47	100	111	500.0
125	15	48	119	131	750.0
150	15	49	149	161	1000.0

(# Weight in grams with box for 300 mm stem length.)

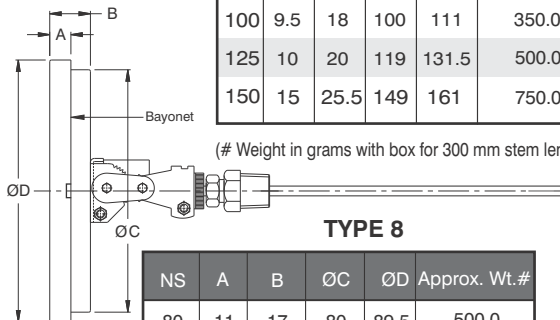
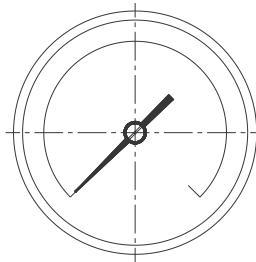

**TYPE 8**

NS	A	B	ØC	ØD	Approx. Wt.#
80	11	17	80	89.5	500.0
100	12.5	19	100	111	750.0
125	15	23	119	129	900.0
150	15	23	149	161	1000.0

(# Weight in grams with box for 300 mm stem length.)

Notes : • Drawings are not to scale. • All Dimensions are in mm. • NS = Nominal Size.

### RANGE, STEM OD & STEM LENGTH SELECTION TABLE

The following table indicates the minimum and maximum stem lengths in mm, per stem diameter per range. The lower values indicated are the minimum immersion length (below thread) for all type of threads. During stem length selection, please select between the limits mentioned below.

(Range) °C	Ø 6 mm/ 6.34 mm.	Ø 8, 9.5 & 10 mm.	Ø 12 mm.
-20 / 40	120 / 500	100 / 600	100 / 600
-20 / 60	100 / 500	80 / 600	80 / 600
-20 / 120	70 / 500	60 / 600	60 / 600
-30 / 30	120 / 500	100 / 600	100 / 600
-30 / 50	100 / 500	80 / 600	80 / 600
-30 / 70	90 / 500	60 / 600	80 / 600
-40 / 40	100 / 500	80 / 600	80 / 600
-40 / 60	90 / 500	80 / 600	80 / 600
-80 / 80	70 / 500	60 / 600	60 / 600
0 / 60	120 / 500	100 / 600	100 / 600
0 / 80	100 / 500	80 / 600	80 / 600
0 / 100	70 / 500	55 / 600	80 / 600
0 / 120	55 / 500	45 / 600	60 / 600
0 / 160	50 / 500	40 / 600	60 / 600
0 / 200	45 / 500	35 / 600	50 / 600
0 / 250	50 / 500	50 / 600	50 / 600
0 / 300	70 / 500	60 / 600	60 / 600
0 / 400	60 / 500	50 / 600	50 / 600
0 / 500	60 / 500	50 / 600	50 / 600

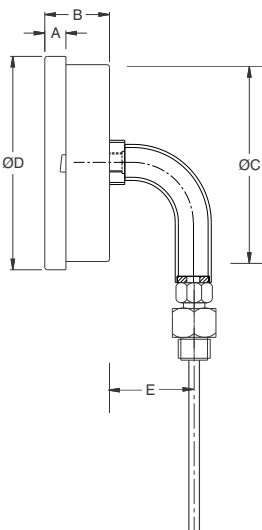
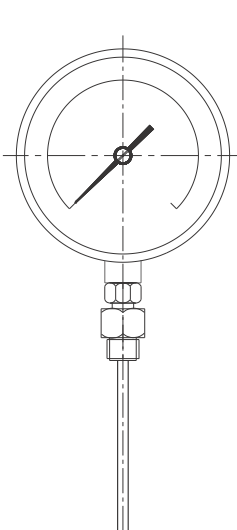

**TYPE 14**

NS	A	B	ØC	ØD	E	Approx. Wt.#
63	12.5	16	66.5	77.5	35	150.0
80	11	17	80	89.5	35	200.0
100	12.5	19	100	111	35	250.0
125	15	21	118.5	129	35	350.0
150	15	21	149	161	35	500.0

**TEMPERATURE GAUGES**

# INDUSTRIAL THERMOMETER

BIMETAL



## MODEL CODE : ECB

### RANGE TABLE

**Note :** Effex offers National / International Scales like °C, °F & Dual Scale in °C & °F & Scales as per the requirement can be provided on request.

Following are the example tables for °C

### STANDARD RANGE

POSITIVE RANGE SINGLE SCALE IN °C									
0/60	0/80	0/100	0/120	0/160	0/200	0/250	0/300	0/400	0/500
COMPOUND RANGE SINGLE SCALE IN °C									
- 20 / 40	- 20 / 60	- 20 / 120	- 30 / 30	- 30 / 50	- 30 / 70	- 40 / 40	- 40 / 60	- 80 / 80	

**Note :** Other Scales are available on request.

### ACCESSORIES (\* Refer Datasheet for Thermowells)

* Thermowell
--------------

### HOW TO ORDER

<b>BASIC MODEL</b>									Example <b>ECB</b>	
<b>NOMINAL SIZE</b>	<b>B</b>	<b>C</b>	<b>D</b>	<b>E</b>	<b>F</b>	<b>G</b>	<b>H</b>		<b>F</b>	
	40 mm	50 mm	63 mm	80 mm	100 mm	125 mm	150 mm			
<b>TYPE OF MOUNTING</b>									<b>2</b>	
<b>2</b> DIRECT BOTTOM ENTRY	X	X	✓	✓	✓	✓	✓	✓		
<b>4</b> DIRECT CENTER BACK ENTRY	✓	✓	✓	✓*	✓*	✓	*	✓*		
<b>8</b> EVERY ANGLE BACK ENTRY	X	X	X	✓*	✓*	✓	*	✓*		
<b>14</b> BOTTOM ENTRY THROUGH ELBOW	X	X	✓	✓*	✓*	✓	*	✓*		
	* Available with external zero adjustment, Refer option RS.									
<b>PROCESS CONNECTION</b>									<b>4NM</b>	
<b>1BM</b> 1/8" BSP(M) (Stem Dia. Max. 6.35 mm)	✓	✓	✓	X	X	X	X			
<b>1NM</b> 1/8" NPT(M)* (Stem Dia. Max. 6.35 mm)	✓	✓	✓	X	X	X	X			
<b>2BM</b> 1/4" BSP(M) (Stem Dia. Max. 6.35 mm)	✓	✓	✓	X	X	X	X			
<b>2NM</b> 1/4" NPT(M)* (Stem Dia. Max. 6.35 mm)	✓	✓	✓	X	X	X	X			
<b>3BM</b> 3/8" BSP(M) (Stem Dia. Max. 10 mm)	X	X	✓	✓	✓	✓	✓			
<b>4BM</b> 1/2" BSP(M)(Standard) (Stem Dia. Max. 12 mm)	X	X	✓	✓	✓	✓	✓			
<b>4NM</b> 1/2" NPT(M)* (Stem Dia. Max. 12 mm)	X	X	✓	✓	✓	✓	✓			
<b>4MM</b> M 20 x 1.5 (Stem Dia. Max. 12 mm)	X	X	✓	✓	✓	✓	✓			
<b>4YN</b> 11/2" TRICLOVER** (Stem Dia. Max. 12 mm)	X	X	✓	✓	✓	✓	✓			
	* Not recommended for Revolving/ Swivel connections. ** Without clamp, gasket & bottom mating part.									
<b>Note : Connections like Metric/ PT/ PF/ Flaired/ UNF/ G/ R etc can be provided on request.</b>										
<b>PROCESS CONNECTION TYPE</b>									<b>ZJ</b>	
<b>ZI</b> ADJUSTABLE	<b>ZJ</b> FIXED (Standard)*	<b>KJ</b> REVOLVING / SWIVEL								
<b>STEM DIAMETER</b>									<b>2C</b>	
<b>1U</b> 6 mm	<b>2M</b> 6.35 mm	<b>2C</b> 8 mm (Standard)	<b>2I</b> 9.5 mm	<b>2J</b> 10 mm	<b>2K</b> 12 mm					
<b>STEM LENGTH (Below thread Max. 600 mm)</b>									<b>100 MM</b>	
PLEASE SPECIFY IN MM (REFER SCALE FOR MINIMUM & MAXIMUM STEM LENGTHS)										
<b>Range</b>									<b>0/100°C</b>	
REFER RANGE TABLE										
<b>OPTIONAL EXTRAS (* APPLICABLE FOR NS 100 MM &amp; ABOVE)</b>									<b>RX - SX</b>	
<b>PS</b> AISI 316 SS CASE & BEZEL (For NS 100 mm & above)*#	<b>RS</b> EXTERNAL ZERO ADJUSTMENT*									
<b>PW</b> FIVE POINT CALIBRATION CERTIFICATE (FOR MEASURING RANGE)	[EXCEPT NS 40 mm, 50 mm & 63 mm (MOUNTING TYPE 2)]									
<b>QA</b> DAMPENING LIQUID SILICON OIL (UP TO 200°C)**	<b>RX</b> SHATTERPROOF / SAFETY GLASS*									
<b>QZ</b> DAMPENING LIQUID SILICON OIL (UP TO 300°C)**	<b>RZ</b> TOUGHENED GLASS*									
<b>RH</b> CUSTOM DESIGNED DIAL	<b>SX</b> SS TAG PLATE									
<b>SW</b> DIAL TAG MARKING*										
<b>GH</b> MATERIAL TEST CERTIFICATES##										

\*\*Gasket & Filling plug of NBR. Refer Price List for Viton. (# Consult factory for minimum order quantity & delivery.)

## MATERIAL TEST CERTIFICATES WILL BE PROVIDED FOR WETTED PARTS ONLY WITH CHEMICAL COMPOSITION TESTING. FOR OTHERS, PLEASE CONSULT FACTORY.

### Ordering Example: ECB - F - 2 - 4NM - ZJ - 2C - 100 mm - 0/100°C - RX - SX

FOR OTHER OPTIONAL ITEMS, PLEASE CONTACT FACTORY FOR DELIVERY AND MINIMUM QUANTITY OF ORDER.

Note : Specifications and dimensions given in this product catalogue represents the state of engineering at the time of printing.

Modifications may take place and materials specified may be replaced by others without prior notice.

**TEMPERATURE  
GAUGES**